

N. B. Brown,

Drag Saw,

No. 39,880,

Patented Sep. 15, 1863.

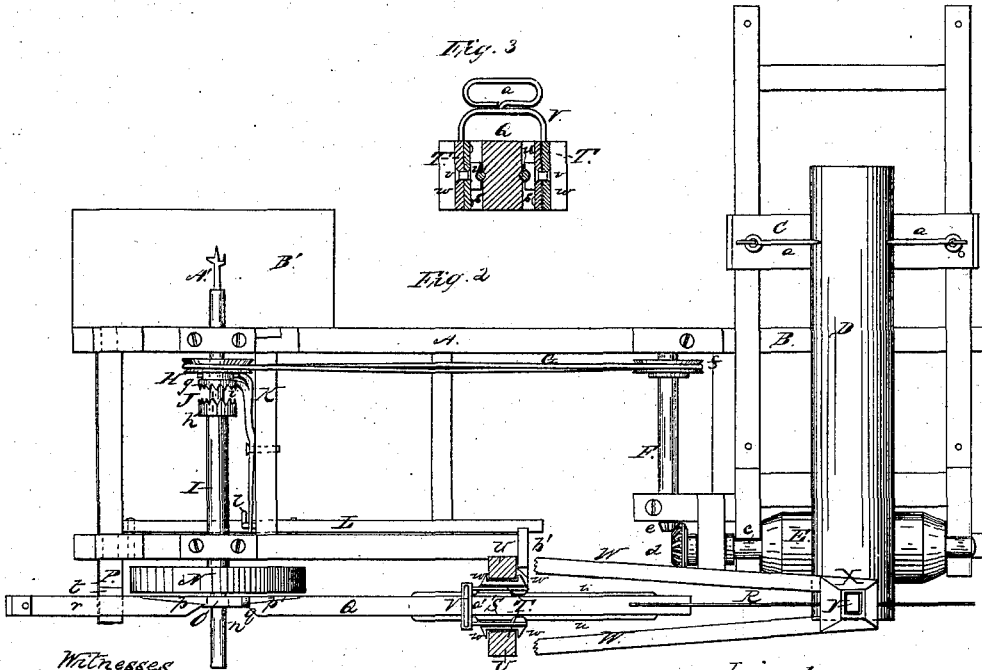
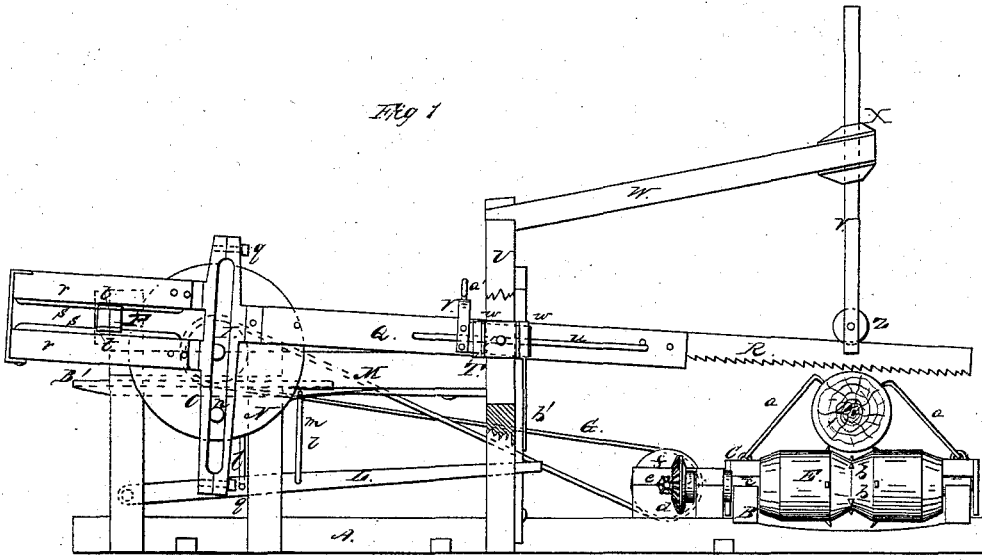

Witnesses
J. W. Coombs
W. R. Rice

Inventor
N. B. Brown
By Munn & Co.

UNITED STATES PATENT OFFICE.

N. B. BROWN, OF ANTWERP, NEW YORK.

IMPROVED SAWING-MACHINE.

Specification forming part of Letters Patent No. 39,880, dated September 15, 1863.

To all whom it may concern:

Be it known that I, N. B. BROWN, of Antwerp, in the county of Jefferson and State of New York, have invented a new and Improved Sawing-Machine; and I do hereby declare that the following is a full, clear, and exact description of the same, reference being had to the accompanying drawings, making a part of this specification, in which—

Figure 1 is a side elevation of my invention; Fig. 2, a plan or top view of the same; Fig. 3, a vertical section of a cross-head pertaining to the same, taken in the line *x x*, Fig. 1.

Similar letters of reference indicate corresponding parts in the several figures.

This invention relates to a new and improved crosscut-sawing machine for sawing fire-wood, &c.; and it consists in a novel and improved arrangement of means for feeding the log to the saw, whereby it is believed that several advantages are obtained over the sawing-machines hitherto devised for the same work or purpose.

To enable those skilled in the art to fully understand and construct my invention, I will proceed to describe it.

A represents a rectangular frame, which supports the saw and its driving parts; and B is a frame which is connected at right angles to A, and supports the log to be sawed. The frame B has a carriage, C, fitted upon it, and arranged in such a manner as to slide freely back and forth thereon. This carriage is provided with two dogs, *a a*, which are fastened into the log D, one on each side of it, and secure the back part of the log on the carriage. On the front part of the frame B there is placed a roller, E, which is grooved circumferentially at its center and provided with teeth *b*. The front part of the log D fits or rests in this groove, the teeth *b* penetrating the log. The carriage C may also be provided with teeth to penetrate the log and prevent the latter slipping on the carriage.

On one end of the shaft *c* of the roller E there is placed a bevel-pinion, *d*, into which a pinion, *e*, on a shaft, F, gears, the shaft F, being at right angles to the roller-shaft *c*, and having a pulley, *f*, upon it, around which a cross belt or rope, G, passes, said belt or rope also passing around a pulley, H, on a shaft, I, in the frame A. The pulley H is placed loosely on the shaft I, and is connected with

the latter when desired by means of a clutch, J, one part, *g*, of which is attached concentrically to the loose pulley H, and the other part, *h*, attached permanently to the shaft I. The part *g* of the clutch has a groove, *i*, made circumferentially in it to receive a forked lever, K, which has its fulcrum *j* in a cross-bar, *k*, of the frame A. This lever K is connected by a rod, *l*, with a lever, L, which is at right angles to lever K, and is connected by a rod, *m*, with a spring, M, the latter having a tendency to keep the part *g* of the clutch J free from the part *h*, and consequently to prevent motion being communicated to the shaft F from the shaft I. The shaft I is the driving-shaft of the machine, and upon its outer end there is secured a pulley, N, having a wrist-pin, *n*, attached to it at any desired distance from its center, according to the length of stroke required for the same.

O represents a metal bar or plate, which has a vertical or nearly vertical slot, *o*, made in it, through which the wrist-pin *n* passes. This bar O is provided with flanges or lugs *p p'*, which project from it at right angles at opposite sides, and the bar O is made in two separate parts and connected by screws *g*. This arrangement is for the purpose of admitting of the wrist-pin *n* being inserted in the slot *o* of the bar or plate O. The plate or lug *p* is attached by bolts or screws to two parallel bars, *r r*, each of which has a way or guide, *s*, attached to its inner surface, and these ways or guides work in grooves made in plates *t t* at opposite sides of a rock-shaft, P, on the frame A. The plate or lug *p'* is bolted to a bar, Q, having the saw R attached to its outer end. This bar Q has a rod, *u*, attached to each side of it, and these rods *u* are fitted and work in grooves made in the inner sides of plates S S, which are attached by pivots *v v* to two slides, T T, fitted on uprights V V, attached to the frame A. The slides T are simply metal plates provided at each end with a lip, *w*, to project over the sides of the uprights V, and the pivots *v* pass centrally through the plates S into the slides T. The plates S S are connected by a bail-shaped bar, V, having a handle, *a'*, attached to it for the purpose of raising the bar Q and saw R when necessary, and the bar and saw may be retained in an elevated position by means of a spring lever-catch, *b'*, or other suitable device. To the up-

per end of each upright V there is attached a bar, W, and the front ends of the latter have a guide, X, secured to them, through which a vertical bar, Y, passes, said bar Y having a pulley, Z, at its lower end, which bears upon the back of the saw R.

From the above description it will be seen that when power is applied to the shaft I a reciprocating motion will be given to the bar Q and saw R, in consequence of the wrist pin *n* of the pulley N working in the slot *o* of the bar O, and the saw will be fed to its work by its own gravity, in connection with the gravity of the bar Q. The pulley Z serves as a guide for the saw R, and the plates S, rods *u u*, ways *s s*, and plates *t t* serve as guides for the bar Q. The latter, as well as the saw, is allowed to fall as the saw cuts in consequence of the slides T working freely on the uprights V V, and the bar Q is allowed to work or adjust itself in a proper relative position, N, at all points in its descent, in consequence of the plates S S being allowed to work on their pivots *v v*, and the shaft P allowed to turn on its bearings. The log D is fed to the saw at any time by raising the lathe so that the bar Q will be retained by the catch *b'*. The operator then depresses the lever L, and thereby throws the part *g* of the clutch in contact with the part *h*, and motion will thereby be communicated to the shaft F from the shaft I, and the roller E will feed the log D along underneath the saw, the movement of the log being stopped at any time by releasing the lever L.

The whole arrangement, it will be seen, is

extremely simple and efficient, and is applicable to all crosscut-sawing.

I would remark that an auger, A', may be inserted in one end of the shaft I, and a table or bed, B', attached to frame A underneath the auger for the purpose of boring articles.

Having thus described my invention, what I claim as new, and desire to secure by Letters Patent, is—

1. The said bar Q, provided with the rods *u u*, and filled between the plates S S, which are attached by pivots *v* to the slides T T on the uprights V V, in connection with the bar or plate O, provided with a slot, *o*, to receive the wrist-pin *n* of the pulley N, and the parallel bars *r r*, provided with ways or guides *s*, fitted in plates *t t*, or an equivalent device, attached to a shaft, P, all arranged substantially as and for the purpose specified.

2. The means employed for giving the feed movement to the log D—to wit, the roller E and carriage C, the log being attached or dogged to the latter, and resting or bearing on the roller, which is rotated at the will of the operator through the medium of the levers L K, clutch J, pulley H, band G, and gearings *d e*, all arranged substantially as and for the purpose specified.

3. The sliding bar I, with pulley Z attached, when used in connection with the saw R and arranged in relation therewith, as and for the purpose specified.

Witnesses: N. B. BROWN.
JOSEPH NEWTON,
D. L. COLLINS.